



Specifications
for
Speaker

GUANGZHOU YUENENG TECHNOLOGY CO., LTD.

CUSTOMER:

MODEL NO. : YN4028-0403

OUR PART NO. . . :

CUSTOMER PART NO. :

CUSTOMER	APPROVED	CHECKED

Add: ,132 Shishu Road, Yuexiu District, Guangzhou City, Guangdong China.

Mobile:+86-18924165988

WhatsApp: +86-18924165988

skype:18924165988

Email: cngzyn@163.com

SPECIFICATION		MODEL NO.	YN4028-0403	Total Page 4
ISSUED DATE	2014/03/25	Updated NO.	2022/05/07	

1. SCOPE

This specification is a typical speaker unit for telephone hand set.

2. GENERAL SPECIFICATIONS

ANALYSIS ITEMS	SPECIFICATIONS
1. TYPE	Dynamic speaker
2. OUT SIDE SIZE	30mm×28mm , Shown Fig.3
3. IMPEDANCE	4Ω ±15% at 1 KHz 2.0Vms Sine Wave
4. RESONANCE FREQUENCY	550±20% Hz at 1.0V Sine wave
5. SENSITIVITY (S. P. L.)	85dB ±3dB at 0.5w/ 0.1m / 10.12.15.20×100Hz average
6. RATED / MAX. POWER	3.0W / 3.5W
7. FREQUENCY RANGE	fo ~ 20kHz
8. DISTORTION	Less than 5 % at 1000Hz 0.6 W
9. UNIT WEIGHT	12.0g±0.1g
10. MEASURING DIAGRAM	Shown in Fig.1
11. FREQUENCY RESPONSE	Shown in Fig.2
12. OPERATING TEMPERATURE	- 30℃ ~ +60℃
13. STORAGE TEMPERATURE	- 40℃ ~ +75℃
14. OPERATION TEST	No one should perceive noise of sine wave 4.0V of 0.3kHz ~ 10kHz .

NO.	DATE	DUE TO	REVISION	SIGNATURE

4. STANDARD TEST CONDITION OF SPEAKER (Fig. 1)

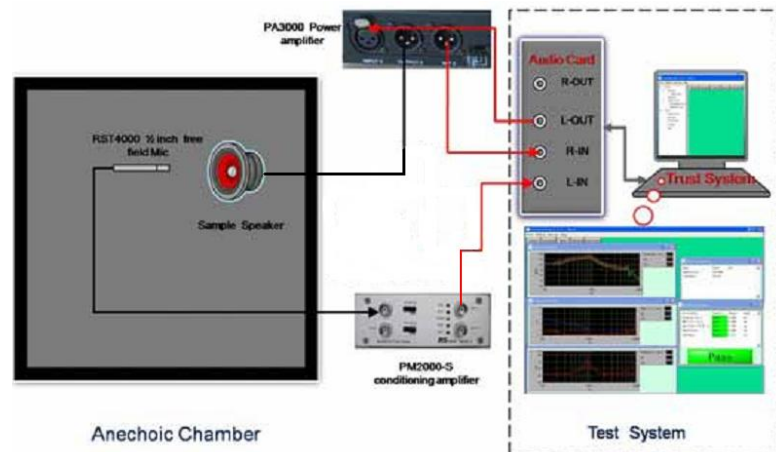

EAKER MODE) (Fig. 2)

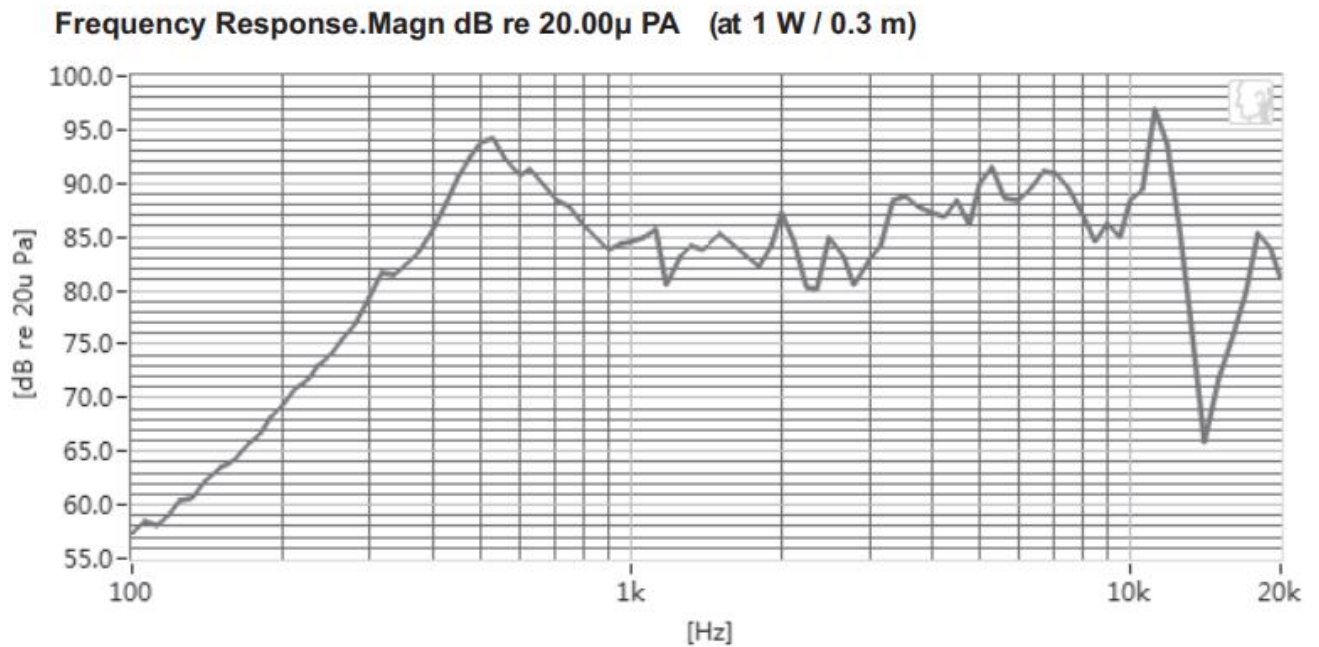

NO.	DATE	DUE TO	REVISION	SIGNATURE

4. ASSEMBLY DIMENSIONS (Fig. 3)

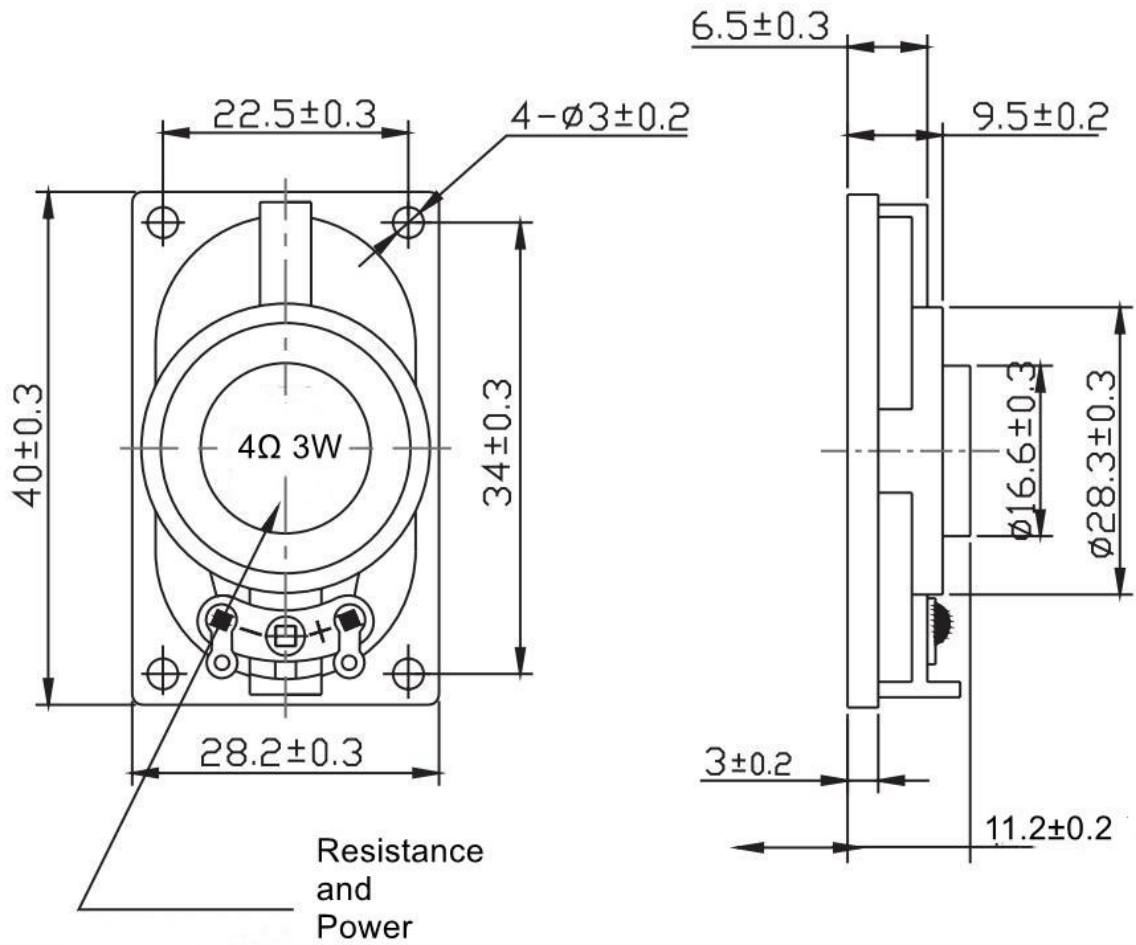

NO.	DATE	DUE TO	REVISION	SIGNATURE

4. PACKING (Fig. 4)

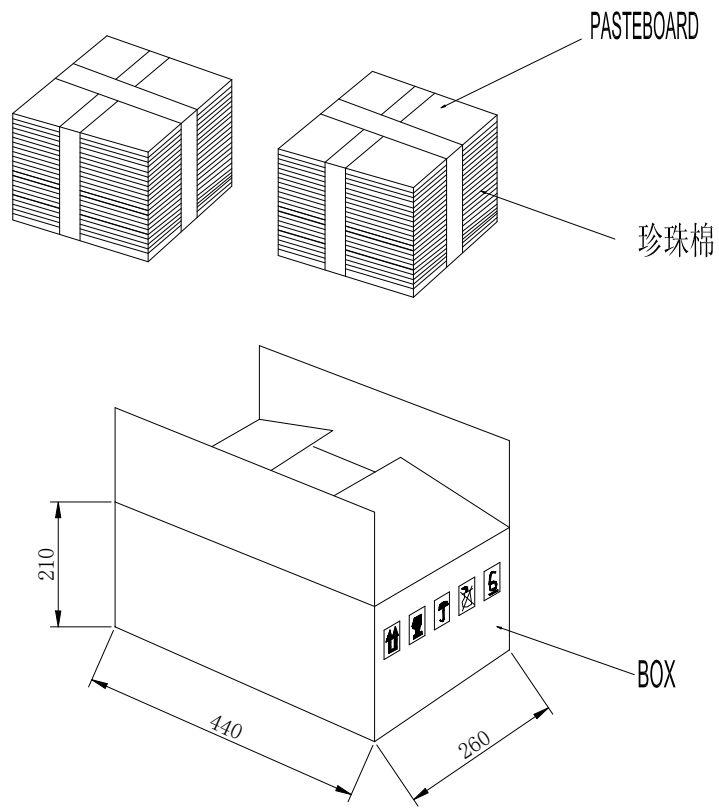

UNIT:MM

NOTES:

1. 100 PCS PER TRAY PE PAN.
2. 2000 PCS PER CARTONS.
3. 2 CARTONS PER BOX.
4. 2000 PCS PER BOX.

NO.	DATE	DUE TO	REVISION	SIGNATURE