



SPECIFICATION OF PRODUCT
承认书

CUSTOMER: _____

DESCRIPTION: Magnetic Buzzer

FUSHENG P/N: YN-DCY9650

CUSTOMER P/N: _____

DATE: _____

CUSTOMER	APPROVER	CHECKER
	Jun Chen	Yong Yang

广州粤能科技有限公司

地址:广东省广州市越秀区诗书路132号

电话: 0086-20-81863202 传真: 0086-20-80724948

邮箱: 2240835001@qq.com

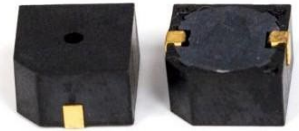

1. SPECIFICATION 规格

No.	Item	Unit	Specification	Condition
1	Oscillation Frequency	Hz	2700±300	
2	Operating Voltage	VDC	2 ~ 5 ; 4 ~ 7 ; 8 ~ 15	
3	Rated Voltage	VDC	3/5/12	
4	Current Consumption	mA	MAX. 30	at Rated Voltage
5	Sound Pressure Level	dB	MIN. 80; MIN. 80; MIN. 85	at 10cm at Rated Voltage
6	Operating Temperature	°C	-20 ~ +70	
7	Storage Temperature	°C	-30 ~ +85	
8	Dimension	mm	9.6x 9.6x H5.0	See appearance drawing
9	Weight (MAX)	gram	1.5	
10	Housing Material		PPS(Black)	
11	Leading Pin		Tin Plated Brass(Au)	See appearance drawing
12	Environmental Protection Regulation		RoHS	

2. APPEARANCE DRAWING 尺寸图

DIENSIONS (UNIT: mm)

Tolerance: ±0.5mm Except Specified

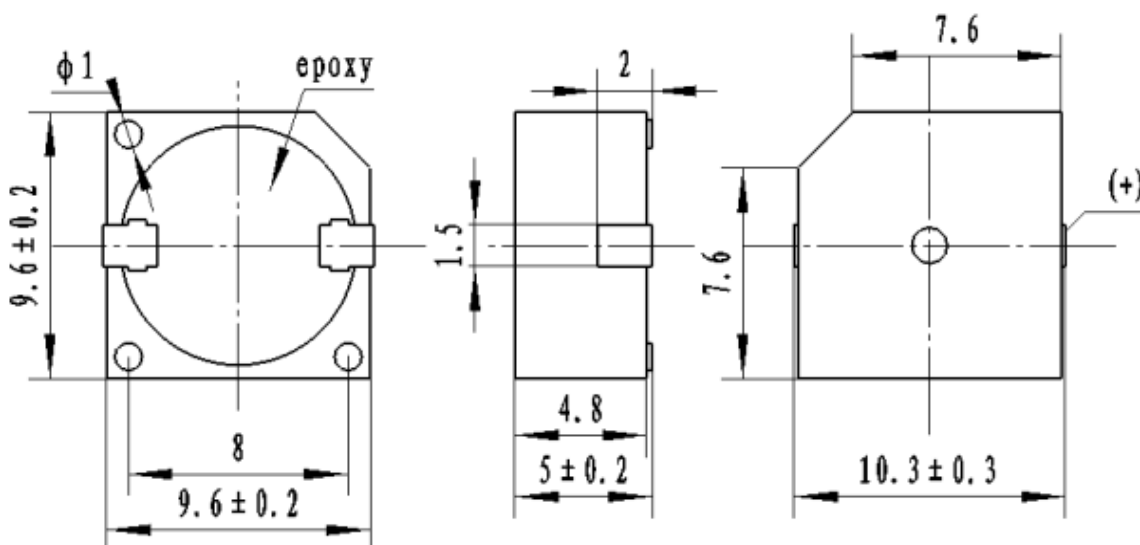

3. TESTING METHOD 测量方式

Standard Measurement conditions

Temperature: $25 \pm 2^\circ\text{C}$ Humidity: 45-65%

Acoustic

Characteristics:

The oscillation frequency, current consumption and sound pressure are measured by the measuring instruments shown below

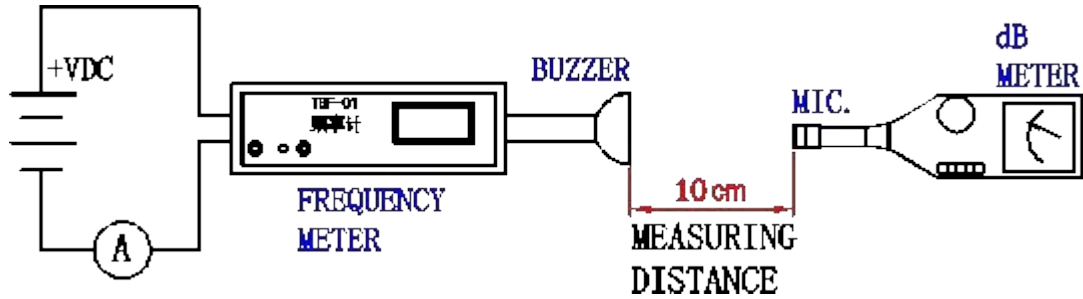

In the measuring test, buzzer is placed as follows:

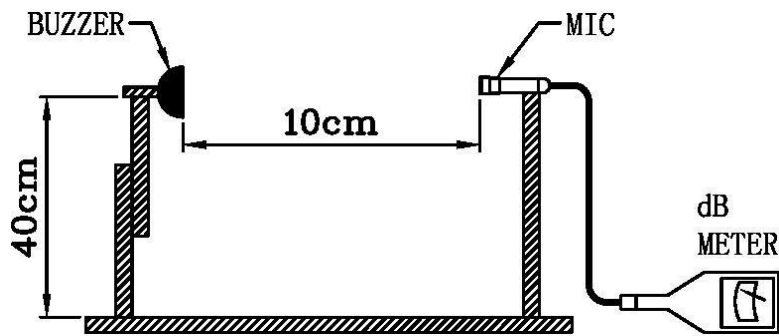

4. VOLTAGE/ CURRENT/ SOUND PRESSURE CHARACTERISTICS

dB-V

mA-V

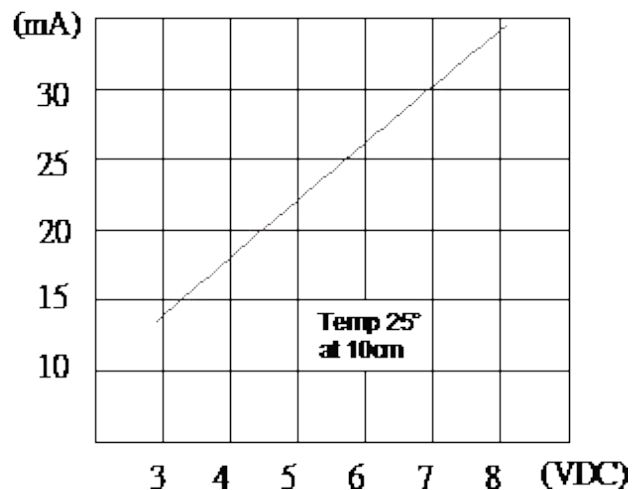
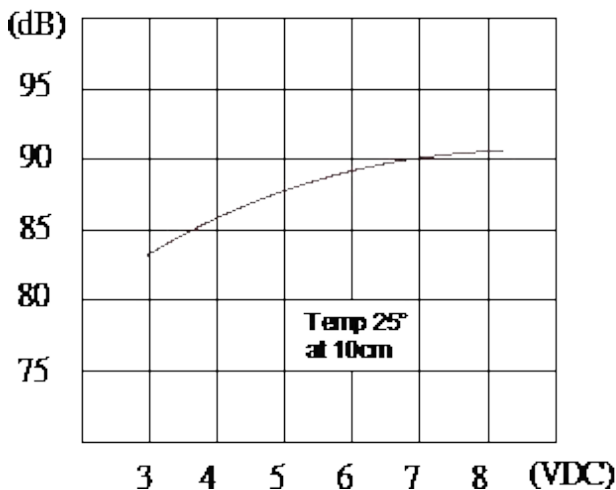

5. Soldering Condition

(1) Recommended reflow soldering condition is as follows
(Reflow soldering is twice)

Note: It is requested that reflow soldering should be executed after heat of product goes down to normal.

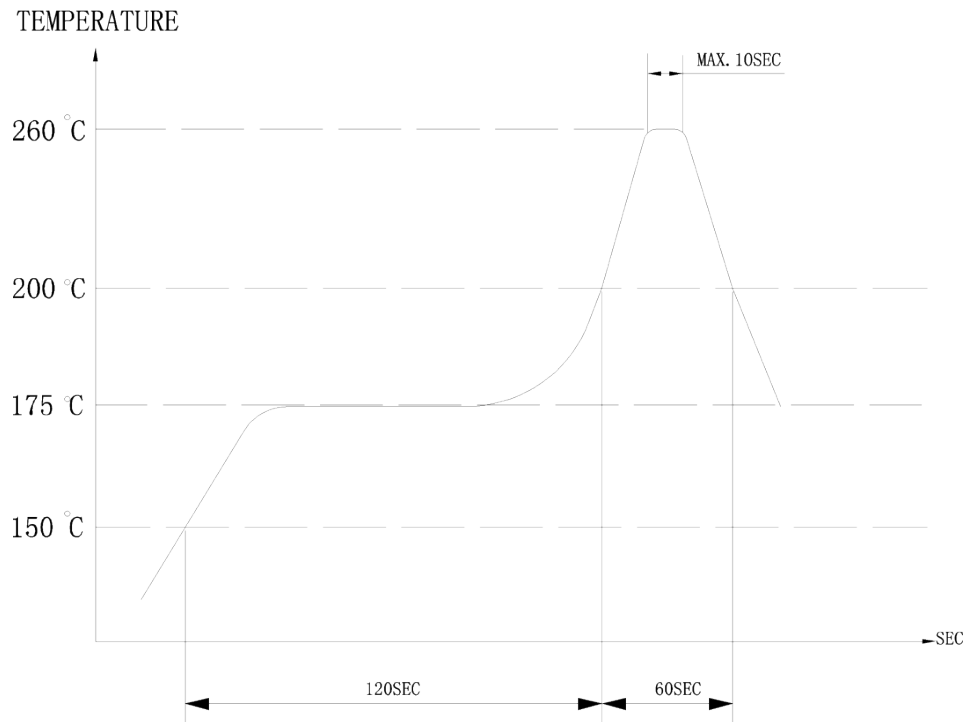

Heat resistant line

(Used when heat resistant reliability test is performed)

(2) Manual soldering

Manual soldering temperature 350 °C within 5 sec.

6. RELIABILITY TEST 可靠性测试

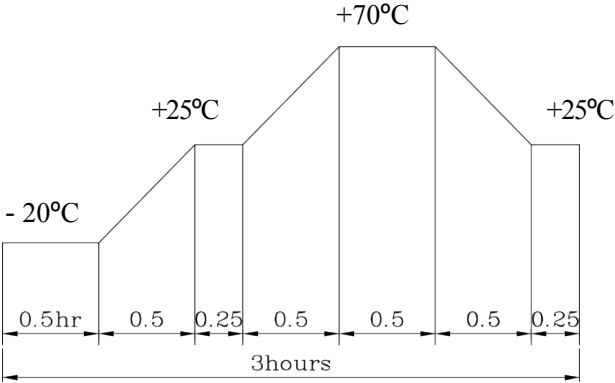
NO.	ITEM	TEST CONDITION AND REQUIREMENT
1	High Temperature Test (Storage)	After being placed in a chamber with 80 °C for 96 hours and then being placed in normal condition for 2 hours. Allowable variation of SPL after test: 10dB.
2	Low Temperature Test (Storage)	After being placed in a chamber with -30 °C for 96 hours and then being placed in normal condition for 2 hours. Allowable variation of SPL after test: 10dB.
3	Humidity Test	After being placed in a chamber with 90-95% R.H. at 40 °C for 96 hours and then being placed in normal condition for 2 hours. Allowable variation of SPL after test: 10dB.
4	Temperature Cycle Test	<p>The part shall be subjected to 5 cycles. One cycle shall consist of:</p>  <p>The diagram shows a temperature cycle profile over a 3-hour period. It starts at -20°C for 0.5 hours, then ramps up to +25°C in 0.5 hours, holds at +25°C for 0.25 hours, ramps up to +70°C in 0.5 hours, holds at +70°C for 0.5 hours, ramps down to +25°C in 0.5 hours, holds at +25°C for 0.25 hours, and finally ramps down to -20°C in 0.5 hours. The total duration is 3 hours.</p> <p>Allowable variation of SPL after test: 10dB.</p>
5	Drop Test	Drop on a hardwood board of 4cm thick, any directions, 6 times, at the height of 75cm. Allowable variation of SPL after test: 10dB.
6	Vibration Test	After being applied vibration of amplitude of 1.5mm with 10 to 55 Hz band of vibration frequency to each of 3 perpendicular directions for 2 hours. Allowable variation of SPL after test: 10dB.
7	Solderability Test	Lead terminals are immersed in rosin for 5 seconds and then immersed in solder bath of +300 °C for 3 seconds. 90% min. lead terminals shall be wet with solder (Except the edge of terminals).
8	Terminal Strength Pulling Test	The force of 9.8N (1.0kg) is applied to each terminal in axial direction for 10 seconds. No visible damage and cutting off.

TEST CONDITION.

Standard Test Condition	:	a) Temperature: +5 ~ +35°C	b) Humidity: 45-85%	c) Pressure: 860-1060mbar
一般测试条件	:	a) 温度: +5 ~ +35°C	b) 湿度: 45-85%	c) 气压: 860-1060mbar
Judgment Test Condition	:	a) Temperature: +25 ± 2°C	b) Humidity: 60-70%	c) Pressure: 860-1060mbar
争议时测试条件	:	a) 温度: +25 ± 2°C	b) 湿度: 60-70%	c) 气压: 860-1060mbar

7. PACKING STANDARD 包装

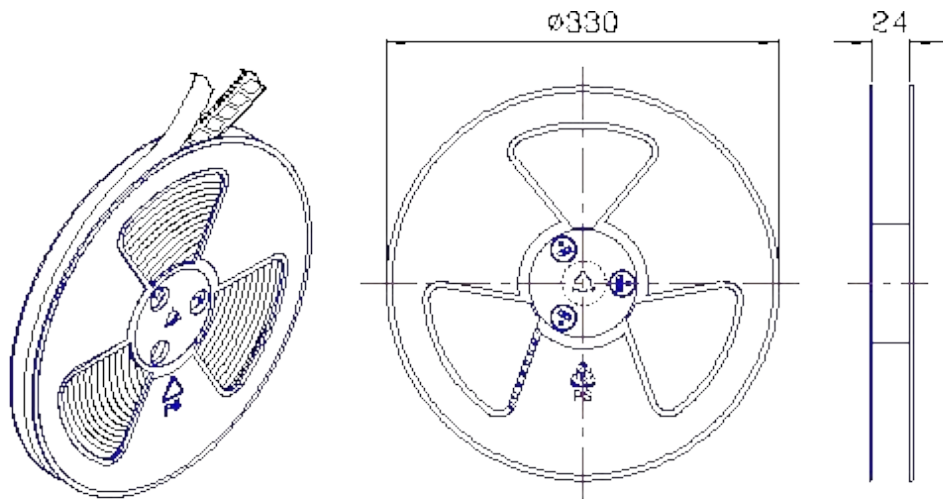

1 Reel : 600PCS

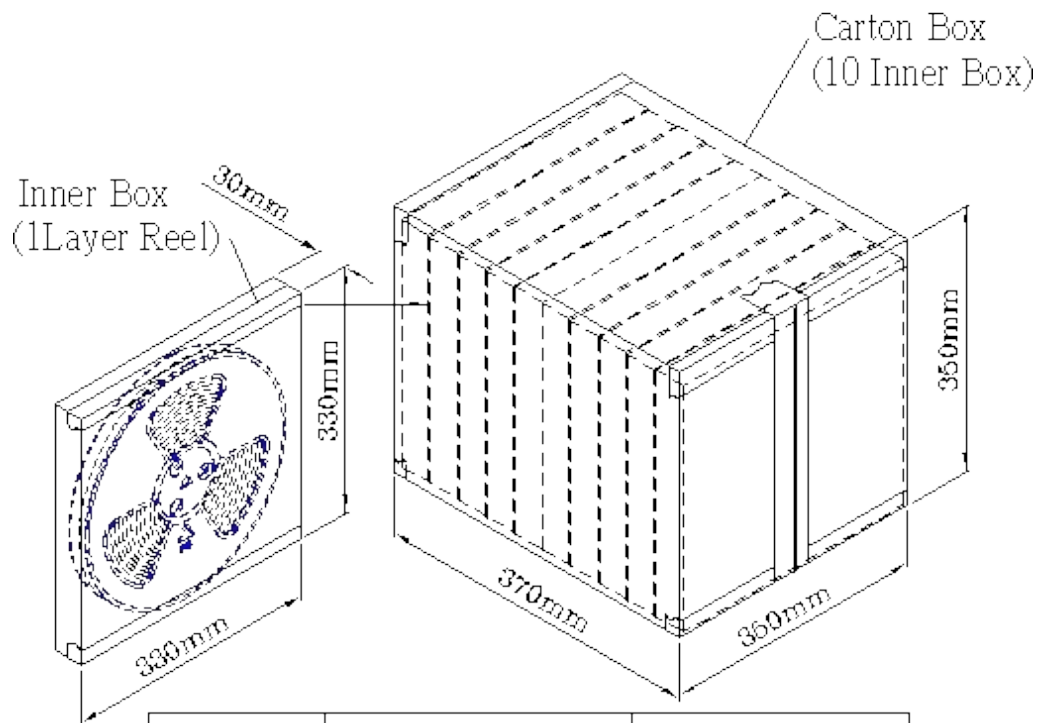
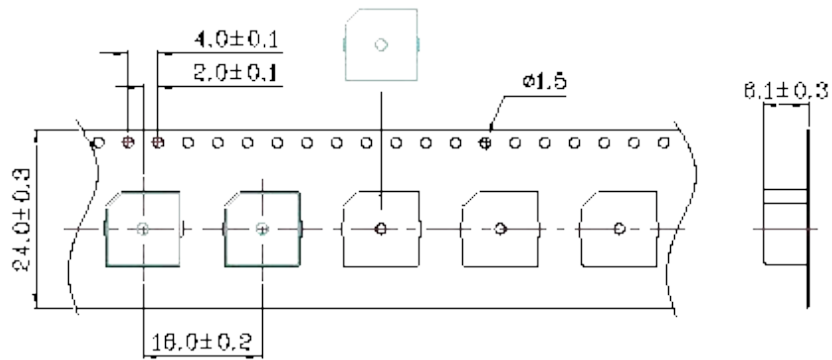

Inner Box	330mmx330mmx30mm	1x600PCS=600PCS
Carton Box	350mmx350mmx370mm	10x600PCS=6,000PCS